



## EBARA PUMP Booster Jet-E

**QUALITY** AUTOMATIC Variable Speed Booster Unit

*Built for comfort living...*



**INVERTER** with integrated PID controller booster pump system

### APPLICATION

- Domestic water supply for villa, house, school, hotel, pent-house, rest house and buildings.
- Industrial water boosting.

### FEATURE / BENEFIT

- ▶ **Constant Pressure**
  - \* PID controller with inverter able to adjust water pressure perfectly by variable speed control.
- ▶ **Energy saving**
  - \* Using of the inverter able to save energy.
- ▶ **No water hammering**
  - \* Preventing water hammer as speed is adjusted automatically to meet variable demand.
- ▶ **Fully tested & assembled unit**
  - \* Ensure trouble- free operation.
- ▶ **Stainless steel pumpset used**
  - \* Hygiene and clean water assured.
- ▶ **Ebara TOTAL warranty on all components used**
  - \* More value for money.
- ▶ **Nationwide Dealers representation**
  - \* After-sale service assurance.



PID Controller  
with inverter

**SPECIFICATION**

Supply Voltage : 1 x 230 Vac  $\pm$ 10% (50Hz)  
 Max liquid temperature : 90 °C  
 Installation : Indoor / Outdoor

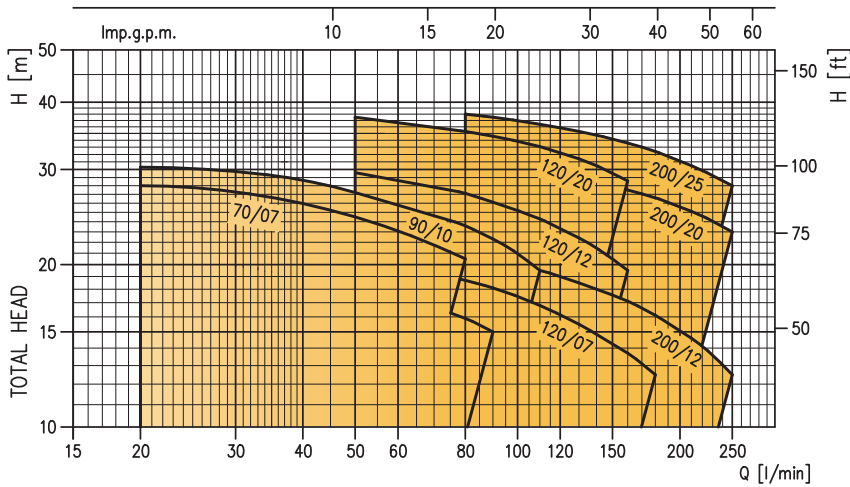

Jet-E 70/07

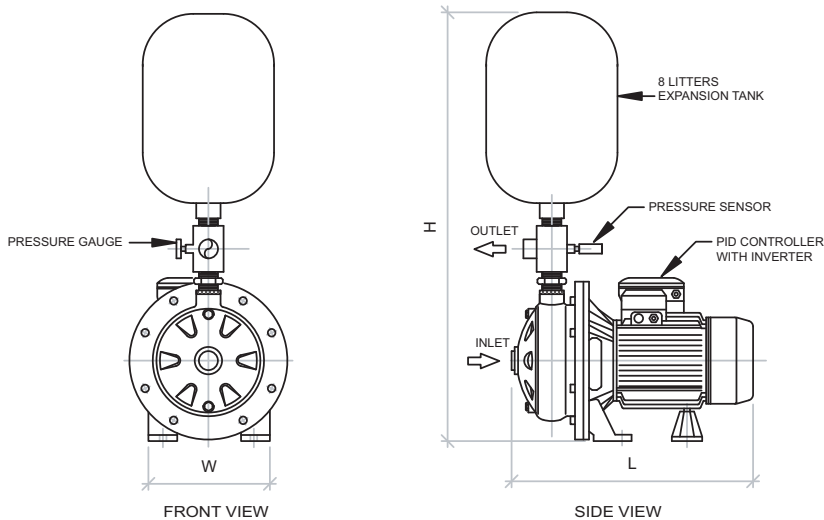

**DIMENSION TABLE**

MODEL	Power (kw)	Dimension (mm)			Weight (kg)
		L	W	H	
70 / 07	0.55	318	160	605	15
90 / 10	0.75	318	160	605	16
120 / 07	0.55	318	160	605	15
120 / 12	0.9	318	160	605	17
120 / 20	1.5	345	180	625	20
200 / 12	0.9	318	160	605	16
200 / 20	1.5	345	180	605	18
200 / 25	1.8	345	180	625	21

\*All specifications are subject to change without prior notice.

**EBARA Pumps Malaysia Sdn Bhd**  
 6, Jalan TP3, UEP Subang Jaya Industrial Park,  
 47620 Subang Jaya, Selangor, Malaysia.  
 Tel : 03-8023 6622 Fax : 03-8023 9355  
 Email : sales@ebar.com.my  
 Website : www.ebara.com.my



Authorised dealer: