

QUALITY Stainless Steel Submersible Pumps

(Single channel impeller that permits 50mm solid passage)

Type DW-DW VOX

APPLICATIONS

- General submersible pumping
- Handling drain water and sewage for communities, hotels, restaurants, etc.
- Emptying pits and discharge into sewers
- Pumping of industrial discharges
- Draining flooded premises
- For automatic dirty water pump stations
- Supplied with 10m cable length type H07RNF
- Available with or without float switch
- Single channel impeller or vortex impeller (VOX type)
- Flanged with or without bracket (F and FZ type)

SPECIFICATIONS

- Maximum liquid temperature : 40°C
- Maximum immersion : 10m
- Maximum passage of solids : 50mm

MATERIALS

- Pump casing, impeller, cover, casing cover and motor casing in AISI 304
- Shaft in AISI 303
- Double mechanical seal with interposed oil chamber: upper in carbon/ceramic/NBR, lower in SiC/SiC/NBR

FEATURES / BENEFITS

- Asynchronous 2 poles motor
- Insulation class : F
- Protection degree : IP68
- 1~230V \pm 10% 50Hz, 3~400V \pm 10% 50Hz
- Permanent split capacitors and automatic thermal overload protection for single-phase version
- Thermal protection to be provided by the user for three phase-version
- DNA 50-DNM 2"
- DNM 50PN10 (F version)



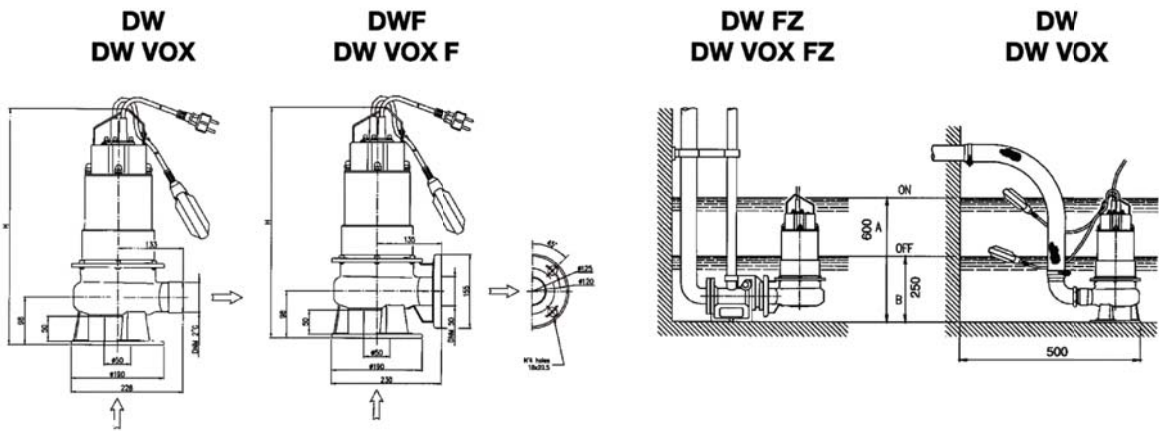
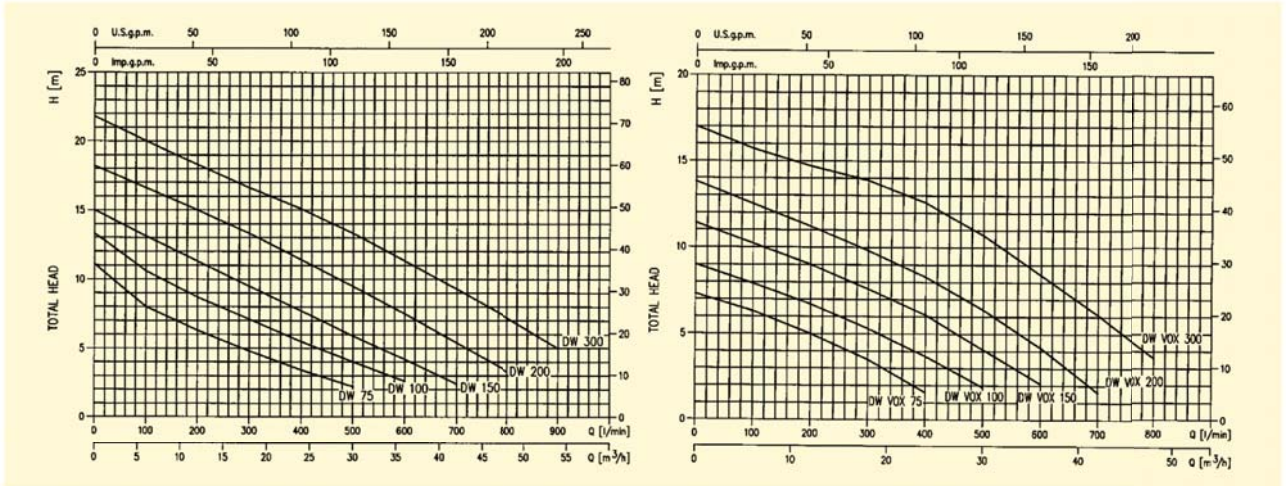

DIMENSIONAL TABLE

| Pump type | Dimensions (mm) | | Weight Kg | Pump type | Dimensions (mm) | | Weight Kg |
|-----------|-----------------|--|--------------|------------|-----------------|--|--------------|
| | H | | | | H | | |
| DW 75 | 485 | | 16 | DW VOX 75 | 485 | | 16 |
| DW 100 | 515 | | 18 | DW VOX 100 | 515 | | 18 |
| DW 150 | 515 | | 20 | DW VOX 150 | 515 | | 20 |
| DW 200 | 515 | | 20 | DW VOX 200 | 515 | | 20 |
| DW 300 | 545 | | 26 | DW VOX 300 | 545 | | 26 |

PERFORMANCE TABLE

| Pump type | | kW | Capacitor | | Absorbed Current (A) | | l/min m³/h | Q = Capacity | | | | | | | | | |
|---------------------------|--------------------------|------|-----------|-----|----------------------|------------|---------------|--------------|------|------|------|------|-----|-----|-----|-----|--|
| Single-phase 230V 50Hz | Three-phase 400V 50Hz | | µF | Vc | 1~ | 3~ 400V | | 100 | 200 | 300 | 400 | 500 | 600 | 700 | 800 | 900 | |
| H=Total head | | | | | | | | | | | | | | | | | |
| DW 75 M | DW 75 | 0.55 | 20 | 453 | 3.9 | 1.5 | 8 | 6.3 | 4.8 | 3.4 | 2.2 | - | - | - | - | | |
| DW 100 M | DW 100 | 0.75 | 25 | 453 | 5.9 | 2.1 | 10.6 | 8.7 | 7.1 | 5.5 | 4 | 2.6 | - | - | - | | |
| DW 150 M | DW 150 | 1.1 | 31.5 | 453 | 7.3 | 2.8 | 13.1 | 11.3 | 9.5 | 7.7 | 5.9 | 4.2 | 2.4 | - | - | | |
| - | DW 200 | 1.5 | - | - | - | 3.6 | 16.6 | 15 | 13.3 | 11.4 | 9.5 | 7.5 | 5.4 | 3.3 | 5 | | |
| - | DW 300 | 2.2 | - | - | - | 5.0 | 20 | 18.3 | 16.6 | 15.1 | 13.3 | 11.3 | 9.3 | 7.2 | - | | |
| DW VOX 75 M | DW VOX 75 | 0.55 | 20 | 453 | 3.9 | 1.4 | 6.3 | 5 | 3.5 | 1.6 | - | - | - | - | - | | |
| DW VOX 100 M | DW VOX 100 | 0.75 | 25 | 453 | 5.8 | 2.1 | 7.9 | 6.7 | 5.3 | 3.7 | 1.9 | - | - | - | - | | |
| DW VOX 150 M | DW VOX 150 | 1.1 | 31.5 | 453 | 7.3 | 2.8 | 10.2 | 9 | 7.6 | 6.1 | 4.1 | 2.1 | - | - | - | | |
| - | DW VOX 200 | 1.5 | - | - | - | 3.3 | 12.5 | 11.2 | 9.8 | 8.3 | 6.4 | 4.2 | 1.6 | - | - | | |
| - | DW VOX 300 | 2.2 | - | - | - | 4.4 | 15.7 | 14.7 | 13.9 | 12.6 | 10.7 | 8.4 | 6.1 | 3.6 | - | | |

*All specifications are subject to change without prior notice.



EBARA Pumps Malaysia Sdn Bhd
 No.6, Jalan TP3, UEP Subang Jaya Industrial Park,
 47620 Subang Jaya, Selangor, Malaysia.
 Tel : 03-8023 6622 Fax : 8023 9355
 Email : sales@ebara.com.my
 Website : www.ebara.com.my



Authorized dealer: